

TRUST SUPER TUNING SYSTEMS AIMED AT REAL COMPETITORS

Greddy

e ENGINE CONTROL UNIT MANAGER
-manage

Ultimate



Take it easy!

Installation Manual

TRUST

1. Table of Contents

Table Of Contents	1
1. Important Information	2 ~ 3
2. Unit Description	4 ~ 5
3. Initial Setup	6 ~ 9
4. How to Splice Wires	10
5. Harness Diagram	11
6. Wiring Power, Ground, Airflow Meter, Throttle, RPM signal	12~13
7. VTEC / Idle Control Valve	14
8. Injector Wires	15 ~ 16
9. Ignition Signal Wire	17 ~ 18
10. Analog Input, Output, / Vehicle Speed Signal	19
11. Crank & Cam Angle / Water & Intake Temp, Knock Signal	20
12. NVCS / Relay Channels	21
13. ECU Location Chart	22
14. ECU Wire Location Chart	23 ~ 36

1. Important Information

Please read this instruction manual carefully, and proceed with the installation ONLY if you fully understand this manual. Make sure to pay attention to all the "Important!" "Warning!" and "Caution!" messages through out the manual.

IMPORTANT!

- This product is legal for sale or use in California only on vehicles which may never be driven on a public highway.
- This product is only for vehicles with 12V (battery) systems.

WARNING!

- Installation of this product should only be performed by a trained specialist, who is very familiar with the automobile's mechanical, electrical, and fuel management systems. If installed by untrained person, it may cause damage to the unit as well as the vehicle.
- Never tune the e-manage Ultimate while the vehicle is moving.
- Never tune the e-Manage Ultimate on public highways. This can be dangerous to you and others on the road.
- When tuning and operating the vehicle in a garage, make sure that the garage is equipped with a proper ventilation system.
- After installation and tuning, make sure to clean up every thing that would interfere the driver. Wires, tools, and laptop computer may interfere with the driver and cause accidents.
- Avoid open sparks, flames, or operation of electrical device near flammable substances.

1. Important Information

Caution!

- Improper tuning of the e-Manage Ultimate can cause damage to the engine.
- GReddy Performance Products, Inc. will not take any responsibility of damage caused by improper installation or tuning.
- Tuning should be performed only by a technician who fully understands the vehicle's fuel management and ignition timing requirement for the engine being tuned.
- Always use a proper air/fuel ratio meter when tuning the e-Manage Ultimate.
- Installation of this product requires modification of the vehicle's electrical system.
- When making wire connections, be sure to remove the key from the ignition, and disconnect the negative terminal of the battery.
- Never short out the system. It can damage the unit as well as the vehicle's electrical system.
- Read and fully understand the wiring diagram before making any wire connection.
- When connecting the connector, push it in all the way until you hear them click in together.

If there are any questions regarding this products, please contact your GReddy Authorized Dealers or GReddy Performance Products, Inc.
9 Vanderbilt, Irvine, CA 92618

2. Unit Description

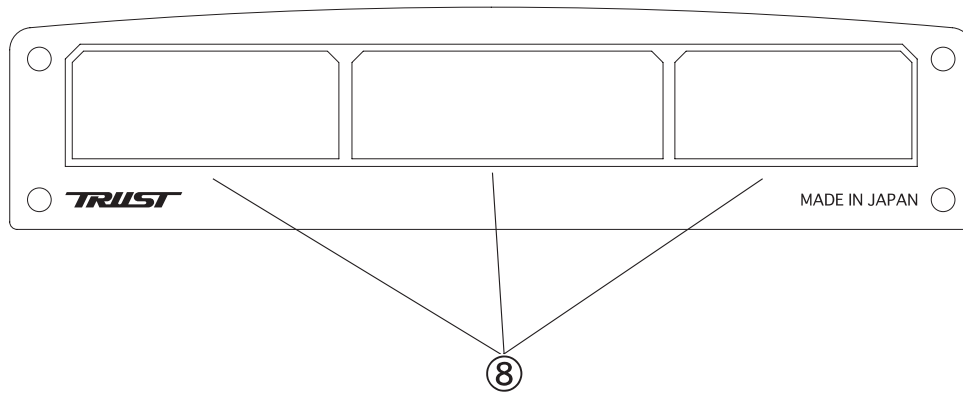
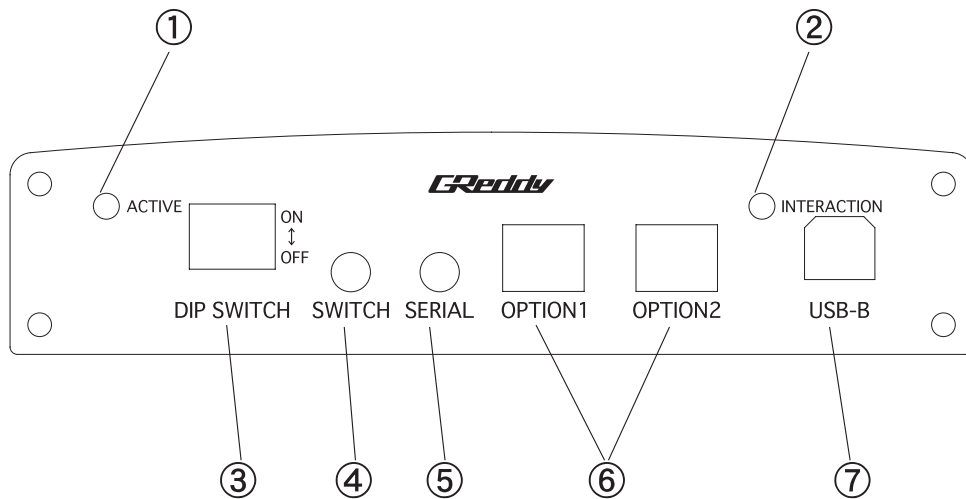

2. Unit Description

① ACTIVE L.E.D

- Steady GREEN - - - - - When the unit recognize Ignition ON
- Flashing GREEN - - - - - When Fouled Plug feature is activated (When engine is started with wide open throttle)
- Quick Flashing RED - - - - - When Self Diagnostic has detected an error
- Flashing RED - - - - - When Warning is activated
- Flashing Orange - - - - - During Main Unit Data Logging

② INTERACTION L.E.D.

- Steady - - - - - When the unit recognize Ignition ON
- Slow Flash - - - - - When confirming engine rpm
- Flashing - - - - - When communicating with PC

③ DIP SWITCH

- Used turn ON/OFF the maps that are set in the Parameter setting (Front Panel)

④ SWITCH

- Used with the Remote Switching System (sold separately) or Switching Harness (Sold separately).

⑤ SERIAL

- Used to link the GReddy Warning Meters with a Data Link Cable (sold separately)

⑥ OPTION1,2

- Used to connect GReddy Pressure Sensor, GReddy Temp Sensor, and/or A/F Input Harness.

⑦ USB-B

- Used to communicate with a PC. Connect the B side of a standard USB cable

⑧ CONNECTOR

- Connect the Plug-in Harness (sold separately) or Universal Harness Kit (sold separately) Connector 14P, 18P, 12P

3. Initial Setup

◎ Jumper Setting

- Before installing the unit, the Jumpers in the unit must be set for vehicle's sensors, and desired maps for the application.

(How to set the Jumpers)

1. Remove the rear panel by removing 4 screws with provided tool.
2. Remove 2 screws on the bottom and slide the board out.
3. Set the Jumpers for the application.
4. After the Jumpers are set, reinstall the board into the case.

Jumper Chart

Jumper No.	Signal Description	OPEN	1 - 2	2 - 3	Factory Setting
JP1	Injector Input / Output Signal CH-1	IN /OUT	Addition Only	-	OPEN
JP2	Injector Input / Output Signal CH-2	IN /OUT	Addition Only	-	OPEN
JP3	Injector Input / Output Signal CH-3	IN /OUT	Addition Only	-	OPEN
JP4	Injector Input / Output Signal CH-4	IN /OUT	Addition Only	-	OPEN
JP5	Injector Input / Output Signal CH-5	IN /OUT	Addition Only	-	OPEN
JP6	Injector Input / Output Signal CH-6	IN /OUT	Addition Only	-	OPEN
JP7	Ignition Input Signal	-	Normal	Honda Distributor	1 - 2
JP8	Ignition Output Signal	-	5V	12V	1 - 2
JP9	Airflow Signal Input / Output	Normal	Mazda Hot Wire	-	OPEN
JP10	Airflow Signal Input 2 / VTEC Output	-	GT-R RB26DETT	VTEC OUT	1 - 2
JP11	OPTION 1	Normal	GReddy Temp Sensor	-	OPEN
JP12	OPTION 2	Normal	GReddy Temp Sensor	-	OPEN
JP13	Knock Signal Input 1 / Water Temp Input	Normal	Pull up	-	OPEN
JP14	Knock Signal Input 2 / Intake Temp Input	Normal	Pull up	-	OPEN
JP15	RPM Signal Input	-	Normal Input	Coil (-)	1 - 2
JP16	Frequency Input / VTEC Input	Karman IN	VTEC IN	VTEC IN (K20A)	OPEN
JP17	Frequency Output / VTM Output	VTM	Karman Output	-	1 - 2
JP18	Injector Input / Output Signal CH1~6	IN / OUT	Addition Only	-	OPEN
JP19	Injector Signal CH-A	I/J Addition	I/J, Sub I/J, NVCS, Relay(-)	-	1 - 2
JP20	Injector Signal CH-B	I/J Addition	I/J, Sub I/J, NVCS, Relay(-)	-	1 - 2

- * When using I/J CH-5 OUT and I/J CH-6 OUT for Sub Injectors, NVCS, or Relay (-) on a 3 ~ 4 cylinder engine, set JP5 and JP6 to OPEN.

⚠ Important

- Make sure to check and confirm that the Jumper setting is correct before installing. Incorrect setting can damage the unit as well as the vehicle's electrical system.

3. Initial Setup

Jumper Setting Description

JP1 Injector Input / Output Signal CH1

This jumper will configure the Injector Input / Output Signal CH1.
Set to "OPEN" when using Injector Adj. Map to trim and add fuel, and set to "1-2" to add only.

JP2 Injector Input / Output Signal CH2

This jumper will configure the Injector Input / Output Signal CH2.
Set to "OPEN" when using Injector Adj. Map to trim and add fuel, and set to "1-2" to add only.

JP3 Injector Input / Output Signal CH3

This jumper will configure the Injector Input / Output Signal CH3.
Set to "OPEN" when using Injector Adj. Map to trim and add fuel, and set to "1-2" to add only.

JP4 Injector Input / Output Signal CH4

This jumper will configure the Injector Input / Output Signal CH4.
Set to "OPEN" when using Injector Adj. Map to trim and add fuel, and set to "1-2" to add only.

JP5 Injector Input / Output Signal CH5

This jumper will configure the Injector Input / Output Signal CH5.
Set to "OPEN" when using Injector Adj. Map to trim and add fuel, and set to "1-2" to add only.

JP6 Injector Input / Output Signal CH6

This jumper will configure the Injector Input / Output Signal CH6.
Set to "OPEN" when using Injector Adj. Map to trim and add fuel, and set to "1-2" to add only.

JP7 Ignition Input Signal

This jumper will configure the unit to recognize the vehicle's Ignition type.
Set to "1-2" for Normal type (pull down type), and "2-3" for Honda Distributor Type (pull up type).

JP8 Ignition Output Signal

This jumper will configure the Ignition output signal.
Set to "1-2" for 5V system and "2-3" for 12V System (Honda distributor Type or some Toyota when tach does not operate properly).

JP9 Airflow Input / Output Signal

This jumper will configure the unit to recognize the vehicle's Airflow meter system.
Set to "OPEN" for normal system (sensor signal increase as airflow increases), and set to "1-2" for Mazda Hot Wire Type system (sensor signal decreases as airflow increases)

JP10 Airflow Signal Input2 / VTEC Output

This jumper will configure the unit for vehicle with 2 airflow meters or for Honda to control VTEC.
Set to "1-2" for GT-R RB26DETT and "2-3" for VTEC.

3. Initial Setup

Jumper Setting

JP11 OPTION 1

This jumper will configure the OPTION 1 port on the Front Panel of the unit.
Set to "OPEN" for Normal type(when used for pressure or A/F sensor), and "1-2" when using GReddy Temp Sensor.

JP12 OPTION 2

This jumper will configure the OPTION 2 port on the Front Panel of the unit.
Set to "OPEN" for Normal type(when used for pressure or A/F sensor), and "1-2" when using GReddy Temp Sensor.

JP13 Knock Signal Input 1 / Water Temp Sensor

This jumper will configure pin 32 channel in the Connector C (14 pin connector).
Set to "OPEN" for Normal type (when used for knock sensor), and "1-2" for pull-up Type (for temp sensor).

JP14 Knock Signal Input 2 / Intake Temp Sensor

This jumper will configure pin 38 channel in the Connector C (14 pin connector).
Set to "OPEN" for Normal type (when used for knock sensor), and "1-2" for pull-up Type (for temp sensor).

JP15 RPM Signal Input

This jumper will configure the unit to recognize the vehicle's rpm signal.
Set to "1-2" for Normal type (Tach signal from ECU), or "2-3" for Coil(-) type.

JP16 Frequency Input / VTEC Input

This jumper will configure pin 13 channel in the Connector B (18 pin connector).
Set to "OPEN" for Karman airflow meter input signal. Set to "1-2" for VTEC input signal, and "2-3" for VTEC input signal for K20A engine.

JP17 Frequency Output / VTM Output

This jumper will configure pin 21 channel in the Connector B (18 pin connector).
Set to "OPEN" for Karman airflow meter output signal. Set to "1-2" for Honda with VTM signal.

JP18 Injector Input / Output Signal CH1~6

This jumper will Configure the Injector Input/Output Signal Ch1~6.
Set to "OPEN" when using Injector Adj. Map to trim and add fuel, and set to "1-2" to add only.

JP19 Injector Signal CH-A

This jumper will configure the Sub Injector Signal CH-A.
Set to "OPEN" when using CH-A for the 7th injector signal for V8 and set to "1-2" for Sub Injector or for NVCS relay.

JP20 Injector Signal CH-B

This jumper will configure the Sub Injector Signal CH-B.
Set to "OPEN" when using CH-B for the 8th injector signal for V8 and set to "1-2" for Sub Injector or for NVCS relay.

3. Initial Setup

Jumper Location

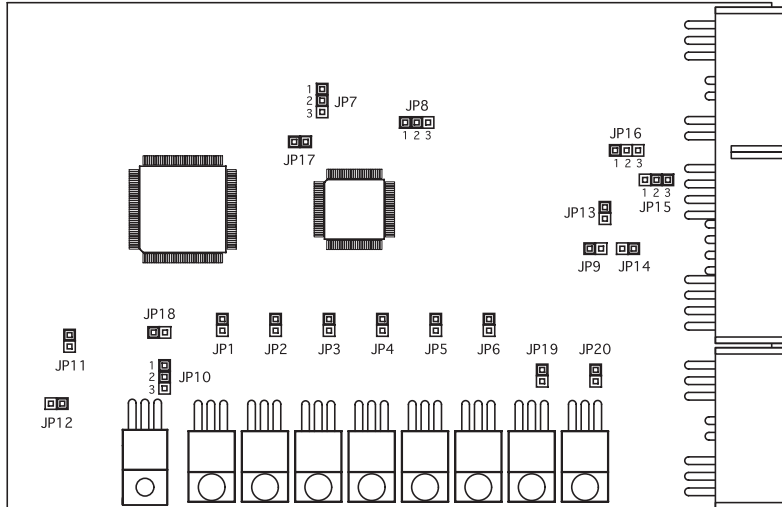

- ※ When Jumping “1-2” or “2-3” make sure to match the pin numbers printed on the circuit board at the corresponding jumper locations.
For “OPEN” make sure the jumper is not jumping the pins at the corresponding jumper locations.
- ※ When setting jumpers to “OPEN” make sure to place the jumper on to one side of the pin to prevent loosing the jumpers.

4. Before Installation

1. Disconnect the negative terminal of the battery.
2. Locate the factory ECU and disconnect the ECU harness connectors. Refer to the ECU location Chart on the back of this manual.
3. Follow the wire diagram for the specific vehicle list on the back of this manual, and connect each harnesses.
4. Inspect all connections and reconnect the ECU harness connector. Reconnect the negative terminal of the battery.

Tools needed

- wire cutter
- Solder and Solder Iron
- Crimper
- Shrink Tube and Electrical Tape

⚠ Caution

- When making any wire connections, DO NOT use any crimp connector or tapping connectors. These connectors will cause poor connections.
- Only use the provided connectors with proper tools or solder all wire connections.

5. How to splice wires

1.Strip the wire as shown.

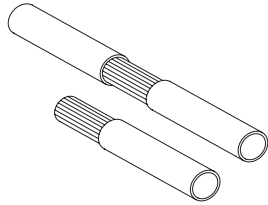

2.Wrap the stripped wire together as shown, and set the crimp in place.
*Crimp is not necessary if soldering.

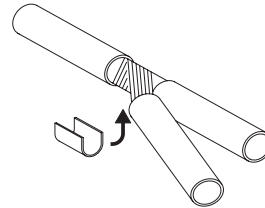

3.Crimp or solder the connection.

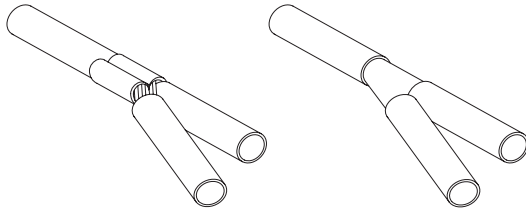

4.wrap the connection with shrink tube or electrical tape.

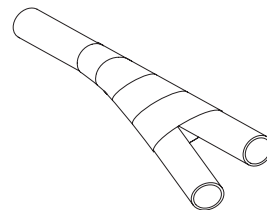

6. How to install the connectors

1.Strip the end of the wire and slip the protective sleeve on.

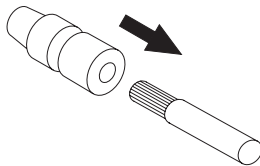

2.Set the connector over the stripped end.

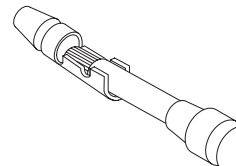

3.Crimp the inside part with proper crimping tool.

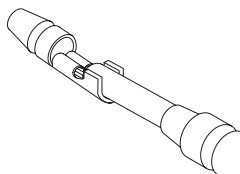

4.Crimp the out side part and slip the protective sleeve over the connector.

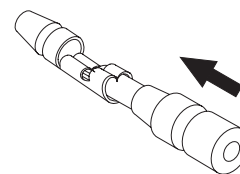

7. Harness Diagram

•Signal wire connection.

Connect the provided signal harness to the vehicle's ECU according to the chart below.

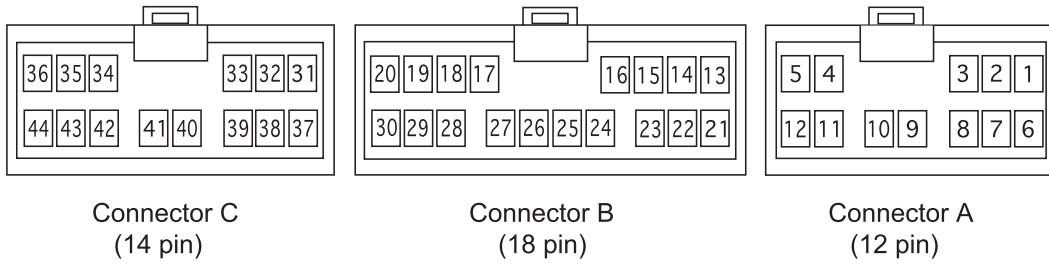

No.	Signal Description	No.	Signal Description	No.	Signal Description
31	Analog (Voltage) Input	13	Airflow (Frequency) Input / VTEC Input	1	Ignition Input Signal CH6
32	Knock Signal 1 / Water Temp Signal	14	Airflow2 (Voltage) Input / VTEC Output	2	Ignition Input Signal CH5
33	Crank Angle Signal Input	15	Airflow1 (Voltage) Input	3	Ignition Input Signal CH4
34	Injector Output Signal CH1	16	Throttle Positoin Sensor Input	4	Ignition Input Signal CH2
35	Injector Output Signal CH2	17	Injector Input Signal CH1	5	Ignition Input Signal CH1
36	Injector Output Signal CH3	18	Injector Input Signal CH2	6	Ignition Output Signal CH6
37	Analog (Voltage) Output	19	Injector Input Signal CH3	7	Ignition Output Signal CH5
38	Knock Signal 2 / Intake Temp Signal	20	Injector Input Signal CH4	8	Ignition Output Signal CH4
39	Cam Angle Signal Input	21	Airflow (Frequency) Input / VTM Output	9	Ignition Output Signal CH3
40	Vehicle Speed Signal Output	22	Airflow1 (Voltage) Output	10	Ignition Input Signal CH3
41	Vehicle Speed Signal Input	23	RPM Input Signal	11	Ignition Output Signal CH2
42	Injector Output Signal CH4	24	Ground (ECU Ground)	12	Ignition Output Signal CH1
43	Injector Output Signal CH5	25	Ignition Power (ECU Power)		
44	Injector Output Signal CH6	26	Injector Input Signal CH7 / A		
		27	Injector Input Signal CH8 / B		
		28	Injector Input Signal CH5 / C		
		29	Injector Input Signal CH6 / C		
		30	Injector Ground (Sensor Ground)		

8. Wiring Power, Ground, Airflow Meter, Throttle, RPM Signal

Hot-wire airflow meter, Flap type airflow meter, or Pressure sensor

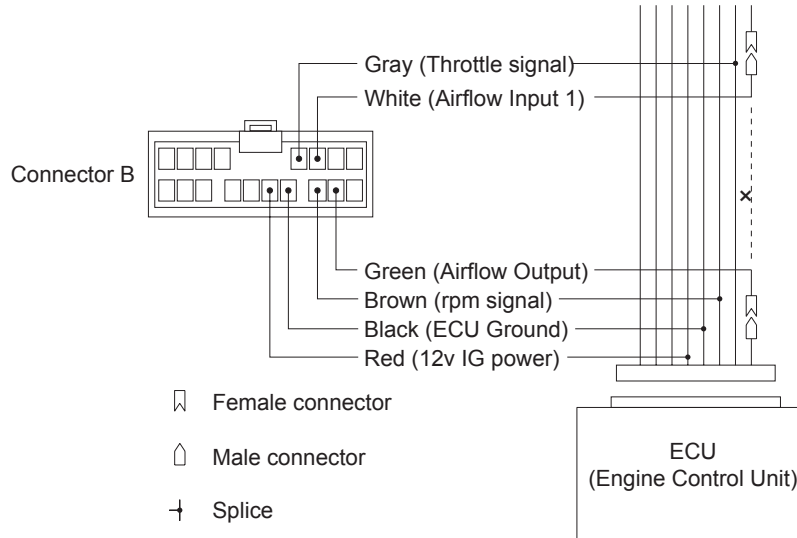

* Always use the provided connectors or solder all connections.

Karman Vortex type airflow meter

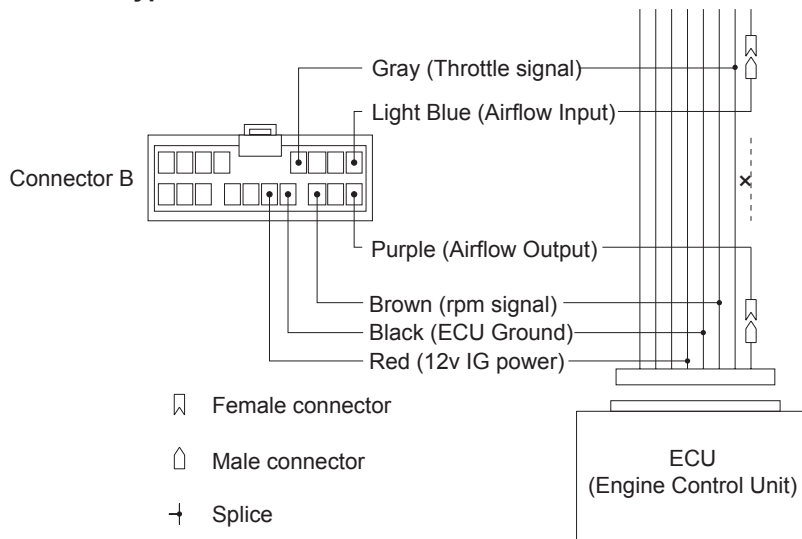

* Always use the provided connectors or solder all connections.

Important

If the Ignition signal, Crank angle signal, or Cam angle signal wire is going to be wired, the unit does not require the rpm signal wire to be connected to pick up rpm signal.

8. Wiring Power, Ground, Airflow Meter, Throttle, RPM Signal

for RB26DETT (with 2 airflow meters)

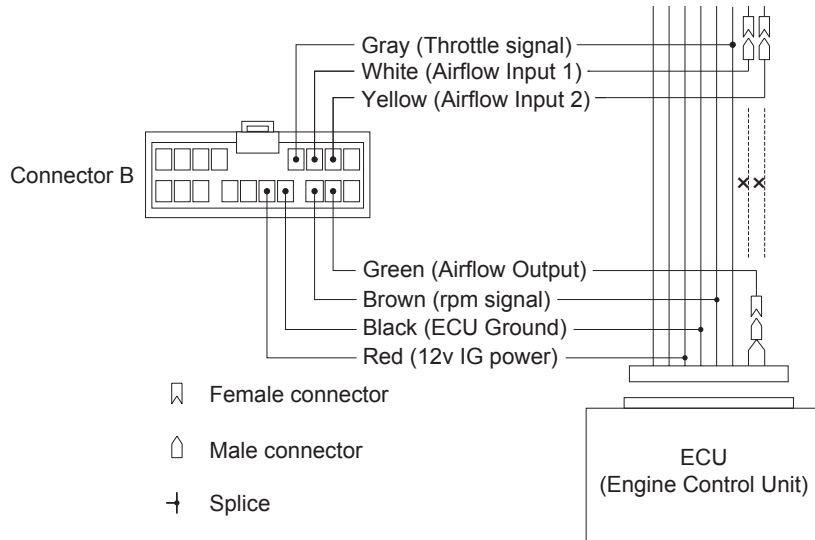

- * The 2 wires for the airflow meter on the ECU will be connected together to the Airflow Output wire.
- * Make sure the jumper JP10 is set to "1-2" in the unit. This activates the Airflow Input 2 wire.
- * Always use the provided connectors or solder all connections.

Important

If the Ignition signal, Crank angle signal, or Cam angle signal wire is going to be wired, the unit does not require the rpm signal wire to be connected to pick up rpm signal.

9. VTEC / Idle Control Valve

for VTEC Equipped vehicle

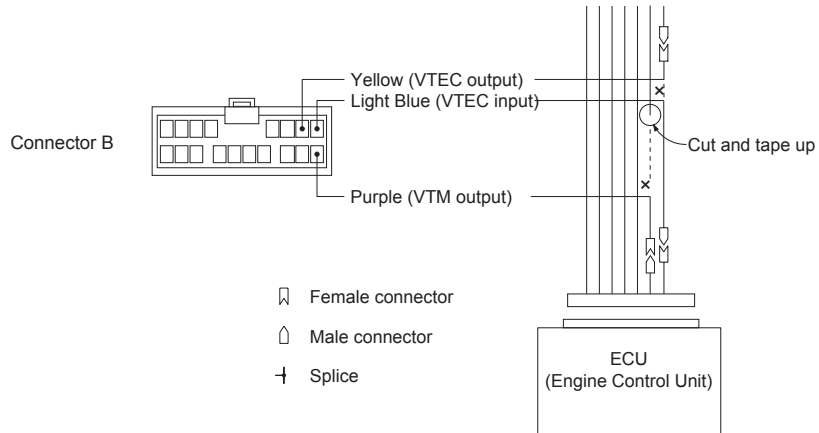

Idle Control Valve wiring

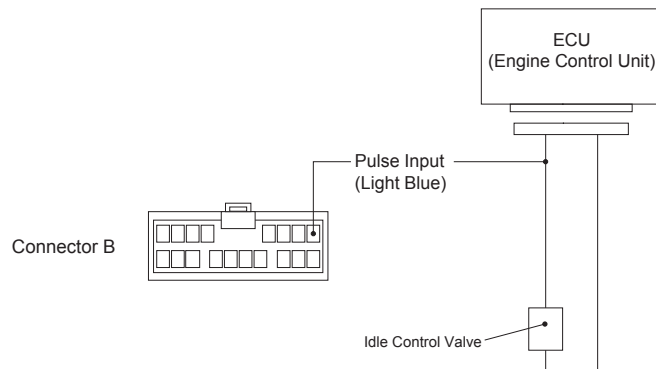

* When using the Idle Adjustment Setting, make sure to set the Jumper JP16 to "OPEN" in the unit

10. Injector Signal Wires

- Wire the injector signal wires for each cylinders. (except for Rotary Engines).
- Normally, the Injector Adjustment will be set to add & trim (jumper JP1~6, 18 set to "OPEN". Inj Adj. Map will be used to add and trim fuel). This can be set for add only. (jumper JP1~6, 18 set to "1-2". Inj Adj. Map will be used to add fuel only)

⊙ examples for ADD / TRIM setup:

- for 6 cylinder individual injection

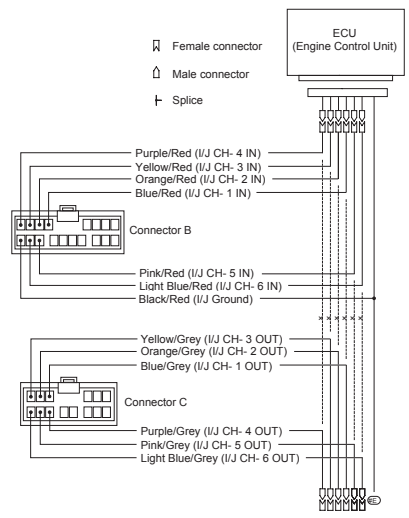

- for 6 cylinder group injection

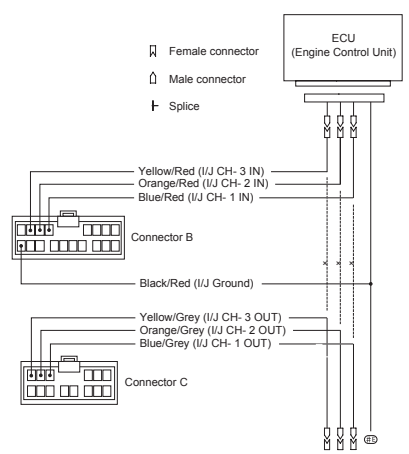

⊙ examples for ADD ONLY setup:

- for 6 cylinder individual injection

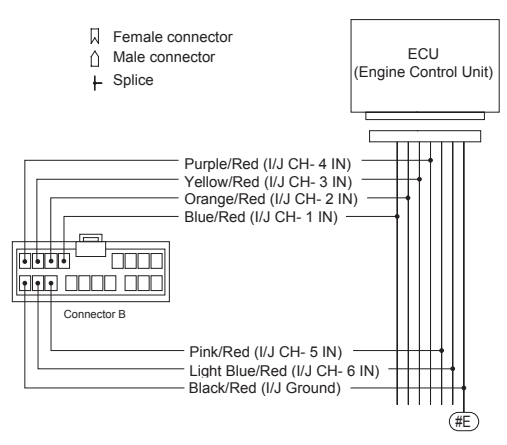

- for 6 cylinder group injection

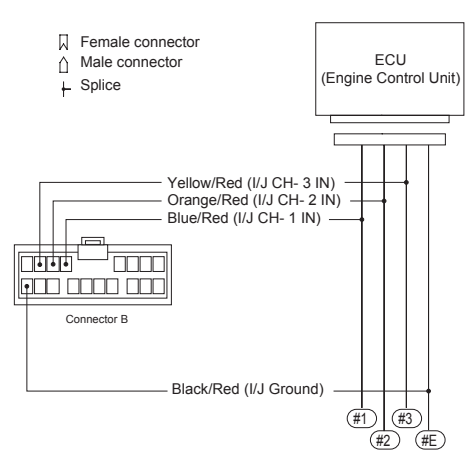

IMPORTANT

On a vehicles with low resistance injectors without dropping resistors (AE86, R31), change the injectors to high resistance injectors or add a dropping resistors.

10. Injector Signal Wires

When changing I/J CH

Example: Changing group injection to sequential injection

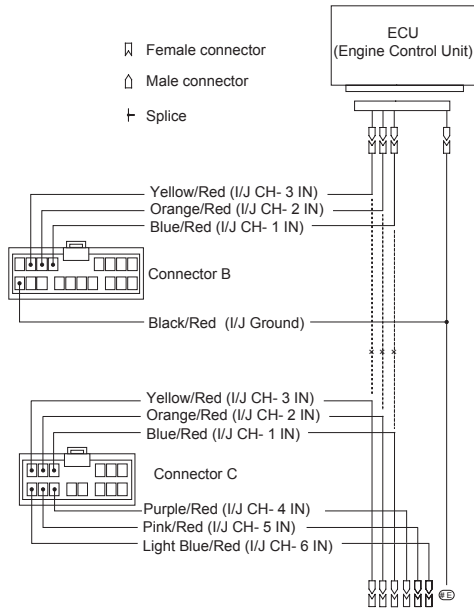

How to connect

- Connect the necessary I/J CH OUT wires to the Connector C.
- The I/J CH Setting must be configured with PC before starting the engine.
- Confirm the injector wiring to match the injection method.

Sub Injector Wiring

When using the CH for sub injectors

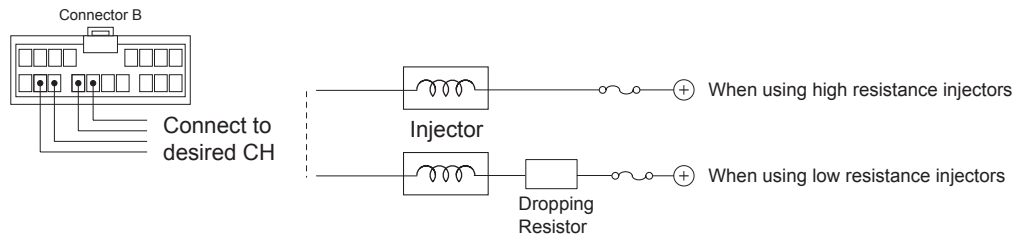

Important

When using low resistance injectors, dropping resistors are required to control the injectors.

11. Ignition Signal Wire

- Connect the e-manage Ignition channels in the engine's firing order shown in the chart below.

(Firing Order Chart)

e-manage Channels	CH1	CH2	CH3	CH4	CH5	CH6
3, 4, 6, 8 cylinder Distributor	t					
3 Cylinder Individual Ignition	t1	t2	t3			
4 Cylinder (Inline) Group Ignition	t1,4	t2,3				
4 Cylinder (Horizontally Opposed) Group Ignition	t1,2	t3,4				
4 Cylinder (Inline) Individual Ignition	t1	t3	t4	t2		
4 Cylinder (Horizontally Opposed) Individual Ignition	t1	t3	t2	t4		
6 Cylinder (Inline) Group Ignition	t1,6	t5,2	t3,4			
6 Cylinder (V6) Group Ignition	t1,4	t2,5	t3,6			
6 Cylinder (Inline) Individual Ignition	t1	t5	t3	t6	t2	t4
6 Cylinder (V6) Individual Ignition	t1	t2	t3	t4	t5	t6
13B (FC3S, JC3SE)	tT	tL				
20B (JCESE)	tT			tL		
13B (FD3S)	tT1	tT2	tL			
13B (SE3P)	tT1	tT2	tL1	tL2		

⚠ IMPORTANT

- make sure the Ignition wires are connected in the proper order shown in the chart above. Improper wiring of the Ignition wires can cause damage to the ignition coils.

Example

- 6 Cylinder individual ignition

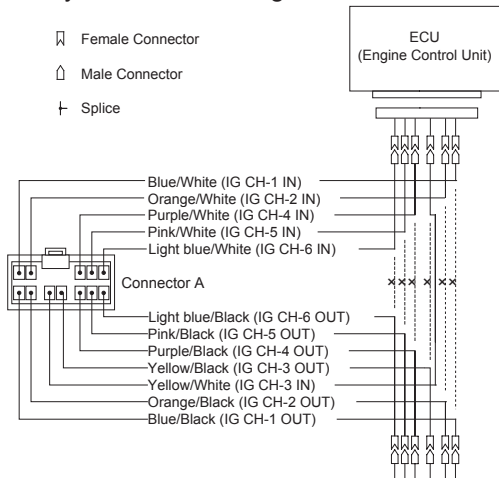

- 4 Cylinder group ignition

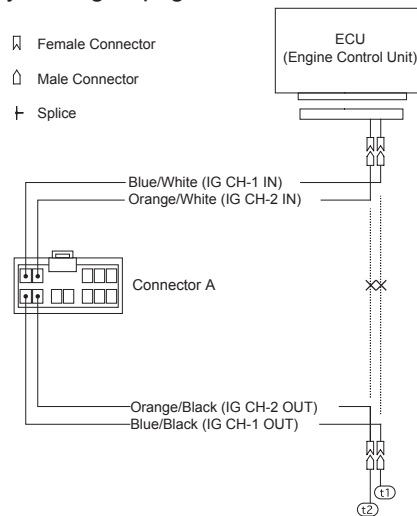

11. Ignition Signal Wire

Distributor Type Ignition

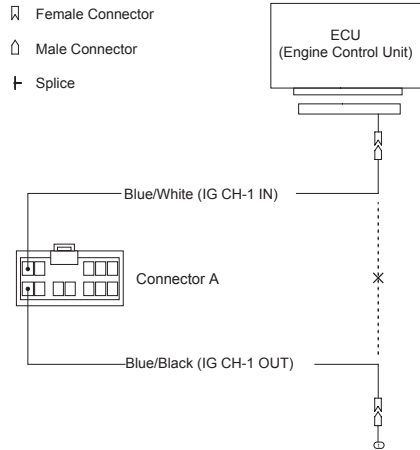

Honda Distributer (with 2 signal)

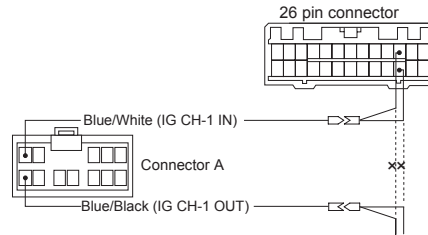

*On Honda EG type vehicles, there are 2 ignition signals in the 26 pin connector. Group the 2 together as shown above.

When changing the IG channel

example: to convert a group ignition system to direct ignition system.

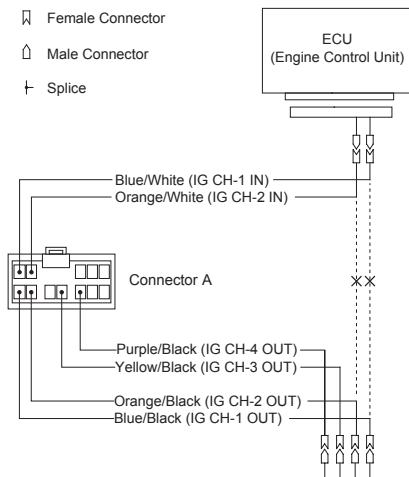

How to connect

- Connect the necessary IG CH OUT wires to the Connector A.
- Please refer to the Ignition firing order chart and Harness Diagram for proper wiring order.
- Confirm the injector wiring to match the ignition method.

12. Analog Input, Output / Vehicle Speed Signal

Analog Input, Output wiring

- These channels can be used on vehicles with airflow meter that uses a map sensor for boost limiter. (Factory controlled boost cut or fuel cut)
- Connect this wire to throttle or accelerator position sensor input, to change feedback range or A/T shift schedule.

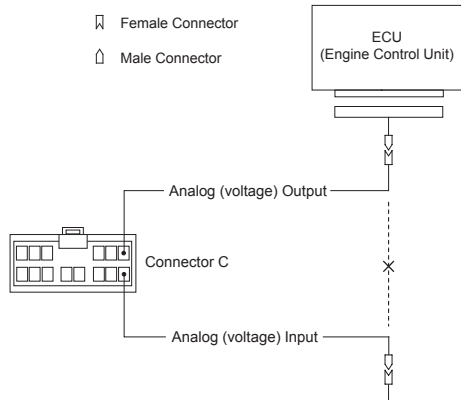

- Pay close attention to the input and output wiring order (direction).
- this channel can also be used for analog input signal only. (for monitoring purpose)

Vehicle Speed Signal wiring

- Connect these wires to eliminate speed cut or when using the vehicle speed adjustment Map. These channels can also be used to monitor the vehicle speed for the data log feature.

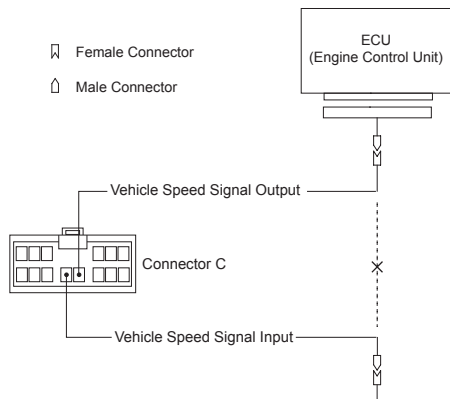

13. Crank & Cam Angle / Water & Intake Temp, Knock Signal

Crank Angle Signal & Cam Angle Signal

- Connect these wires for e-manage Ultimate to recognize the rpm signal from crank and cam angle signal if there are no tach signal out put from the ecu. Also. by connecting these wires Ignition timing can be monitored in the data log feature.

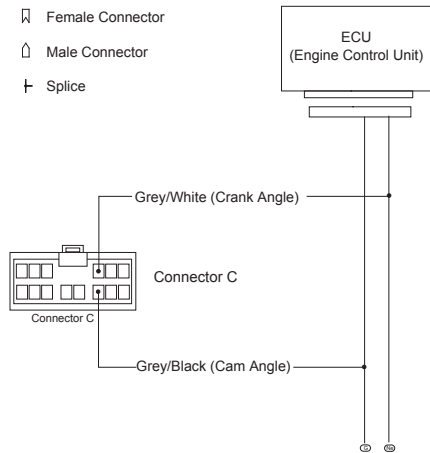

IMPORTANT

If the Crank and Cam angle signal wires are connected to the ecu, e-manage will recognize the rpm without connecting the rpm signal wire.

Knock 1 - 2, Water Temp Signal, Intake Temp Signal

- Connect these wire to the ECU Knock, water temp, or intake temp sensor signal to monitor them in the data log feature.
- Also by connecting these wire to the water temp and/or intake temp signal the temperature condition can be set in the software to activate relays with selected relay channels.

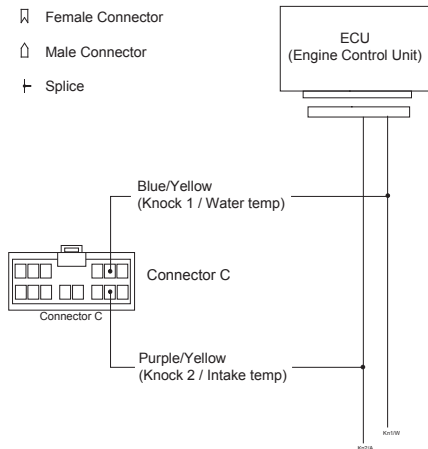

14. NVCS / Relay Channels

NVCS (Nissan Valve Control System)

- Connecting one of these channels to the NVCS solenoid to control the NVCS.

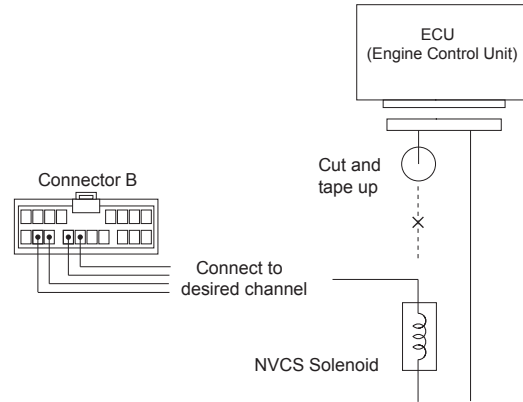

- Make sure the wire that was cut is taped up to prevent any short.
- When using this feature the proper channels must be configured in the "I/J" set up in the Parameter setting in the software and make the necessary jumper setting to activate these channels.

Relay

- These channels can be used for relays to activate desired devices.

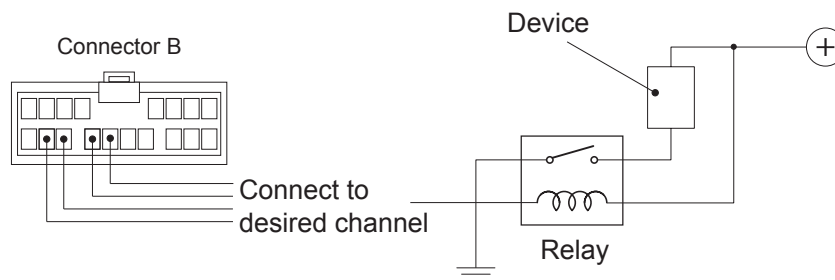

- When using this feature the proper channels must be configured in the "I/J" set up in the Parameter setting in the software and make the necessary jumper setting to activate these channels.

15. ECU Location Chart

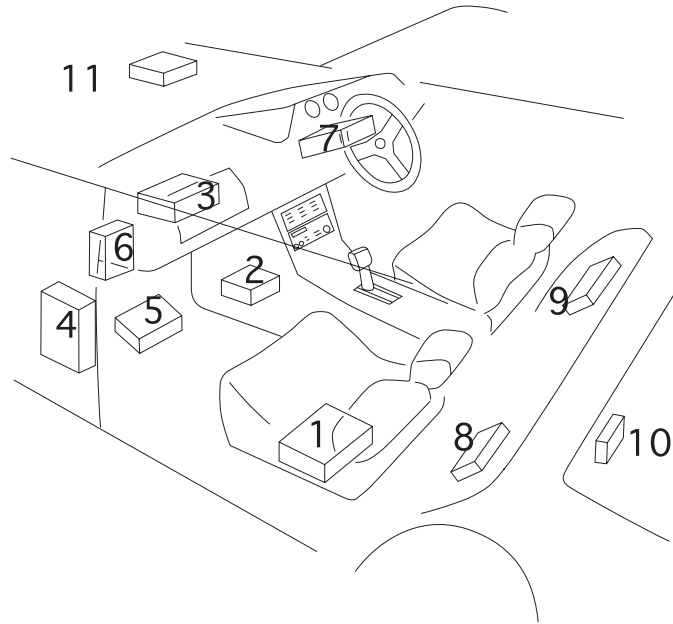

Channel Symbol Description

(+B) ← Power	(Ne) ← Crank Angle Signal	(I · t) ← RPM & Ignition Signal
(E) ← Ground	(G) ← Cam Angle Signal	(t※ · ※) ← No. ※ & No. ※ Ignition Signal
(I) ← RPM Signal	(A) ← Intake Temp Signal	(tL※) ← No. ※ Leading Ignition Signal (F : front, C : Center, R : Rear)
(Th) ← Throttle Signal	(W) ← Water Temp Signal	(tT※) ← No. ※ Trailing Ignition Signal (F : front, C : Center, R : Rear)
(Ar) ← Airflow/map Sensor Signal	(Kn※) ← No. ※ Knock Signal	(#P※) ← No. ※ Primary Injector Signal (F : front, C : Center, R : Rear)
(VT) ← VTEC Signal	(P) ← Absolute Pressure Sensor Signal	(#S※) ← No. ※ Primary Injector Signal (F : front, C : Center, R : Rear)
(VM) ← VTM Signal	(SPD) ← Vehicle Speed Signal	
(#E) ← Sensor Ground	(#※) ← No. ※ Injector Signal	
	(t※) ← No. ※ Ignition Signal	

16. ECU Wire Location Chart

TOYOTA / LEXUS

Model	Chassis Code	Year	Engine Code	Sensor Type	CP #	ECU Location	
ARISTO	JZS161	97.8~	2JZ-GTE	TY_HW-5	T-17	11	
	JZS147	91.90~97.7		TY_PR-1	T-15	5	
SOARER	JZZ30	91.5~96.7	1JZ-GTE	TY_PR-1	T-13	5	
	GZZ20	88.1~91.4	1G-GTE	TY_FL-3	T-1	3	
SUPRA	JZA80	93.5~97.7	2JZ-GTE	TY_PR-1	T-15US	5	
	JZA70	90.8~93.4	1JZ-GTE		T-10		
MARK 2	JZX110	00.9~	1JZ-GTE	TY_HW-6	T-17	2	
	JZX100	96.9~00.8		TY_HW-4	T-16		
	JZX90	94.9~96.8		TY_PR-1	T-19		T-13
		92.10~94.8					
	JZX81	90.8~92.9		TY_PR-1	T-10	3	
MR-S	ZZW30	99.10~	1ZZ-FE	TY_HW-1	T-22	8	
MR-2	SW20	93.10~99.7	3S-GTE	TY_PR-2	T-2	10	
		89.10~93.9		TY_FL-2			
		93.10~97.12	3S-GE	TY_PR-3	T-11		
		89.10~93.9		T-2			
	AW11	86.8~89.9	4A-GZE	TY_FL-4	T-5		
		84.6~89.9	4A-GE	TY_PR-3	T-3		
CELICA	ZZT231	99.9~	2ZZ-FE	TY_HW-1	T-22	11	
	ZZT230		1ZZ-FE				
	ST205	94.2~99.7	3S-GTE	TY_PR-2	T-2	2	
	ST202/203	93.10~97.11	3S-GE	TY_PR-3	T-11		
ALTEZZA	SXE10	98.10~	3S-GE	TY_HW-1	T-14	11	
	GXE10		1G-FE	TY_PR-3	T-18		
	JCE10		2JZ-GE	TY_HW			
LEVIN	AE111	95.5~00.7	4A-GE	TY_PR-3	T-2	2	
	AE101	91.6~95.4	4A-GE	TY_FL-1	T-8		
			4A-GE(A/T)	T-2			
			4A-GE	TY_PR-3	T-7		
	AE92	89.5~91.5	4A-GE	TY_PR-3	T-7		
	AE86	87.5~89.4	4A-GE	TY_PR-3	T-3		
83.5~87.4					4		
STARLET	EP91	95.12~91.12	4E-FTE	TY_PR-1	T-9	6	
	EP82	89.12~95.11	4E-FTE(M/T)		T-6	2	
		92.1~95.11	4E-FTE(A/T)		T-7		
		89.12~91.12	4E-FTE(A/T)		T-6		
ESTIMA	MCR30/40	00.1~	1MZ-FE	TY_HW-1	T-20	4	
	ACR30/40	00.3~	2AZ-FE	TY_HW-1	T-23		
VITZ	NCP13	00.10~02.7	1NZ-FE	TY_HW-3	T-12	6	
	NCP10/15	99.8~	2NZ-FE				
	SCP10	99.1~	1SZ-FE				TY_HW-2
xA / xB	NCP61/31	03.2~	1NZ-FE	TY_HW-3	T-21	6	
tC	FW21	04.1~	2AZ-FE	TY_HW-3	T-21US	6	

Some of these information are for Japanese spec Vehicles. Please refer to you factory service manual.

16. ECU Wire Location Chart

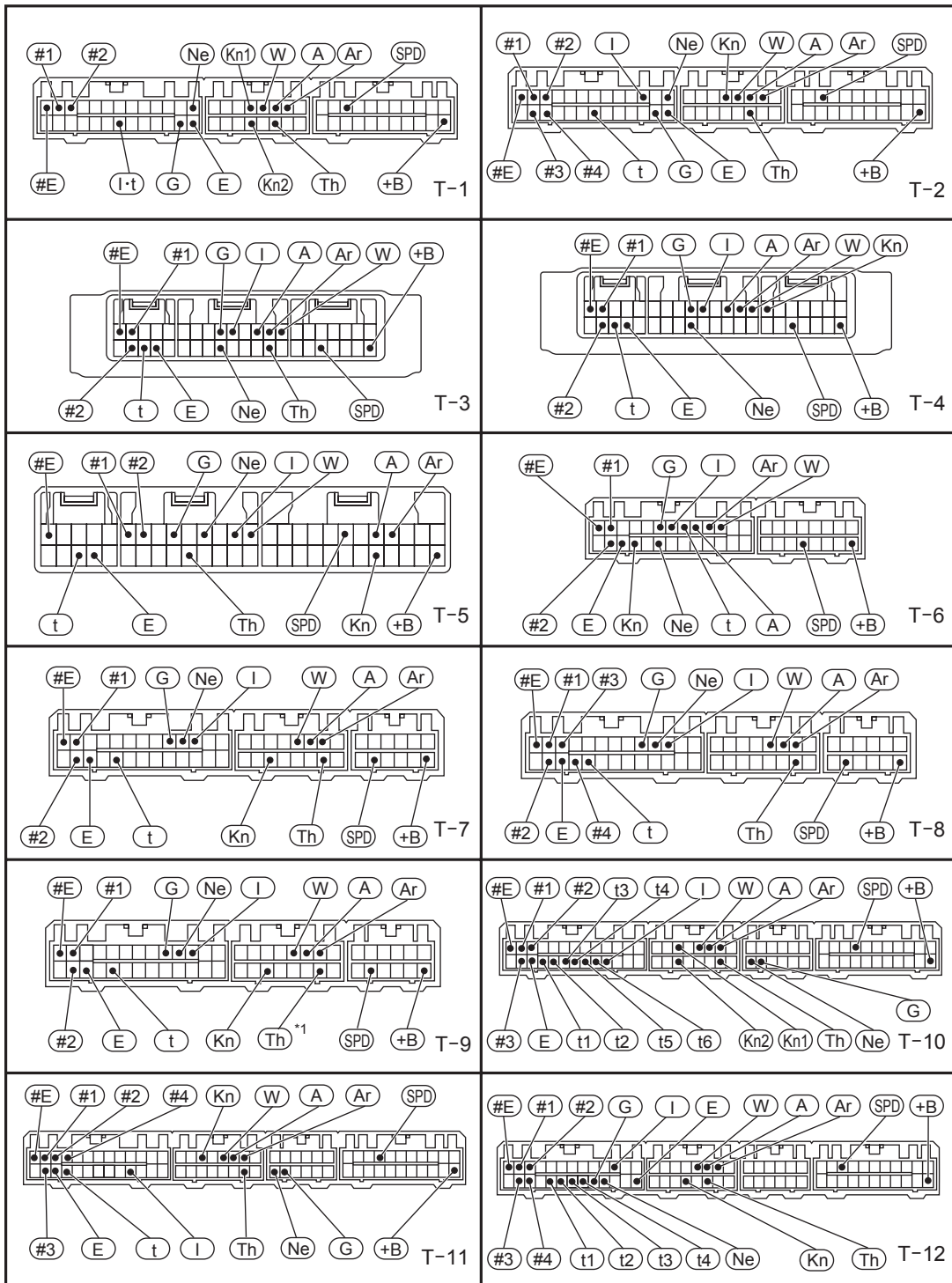

16. ECU Wire Location Chart

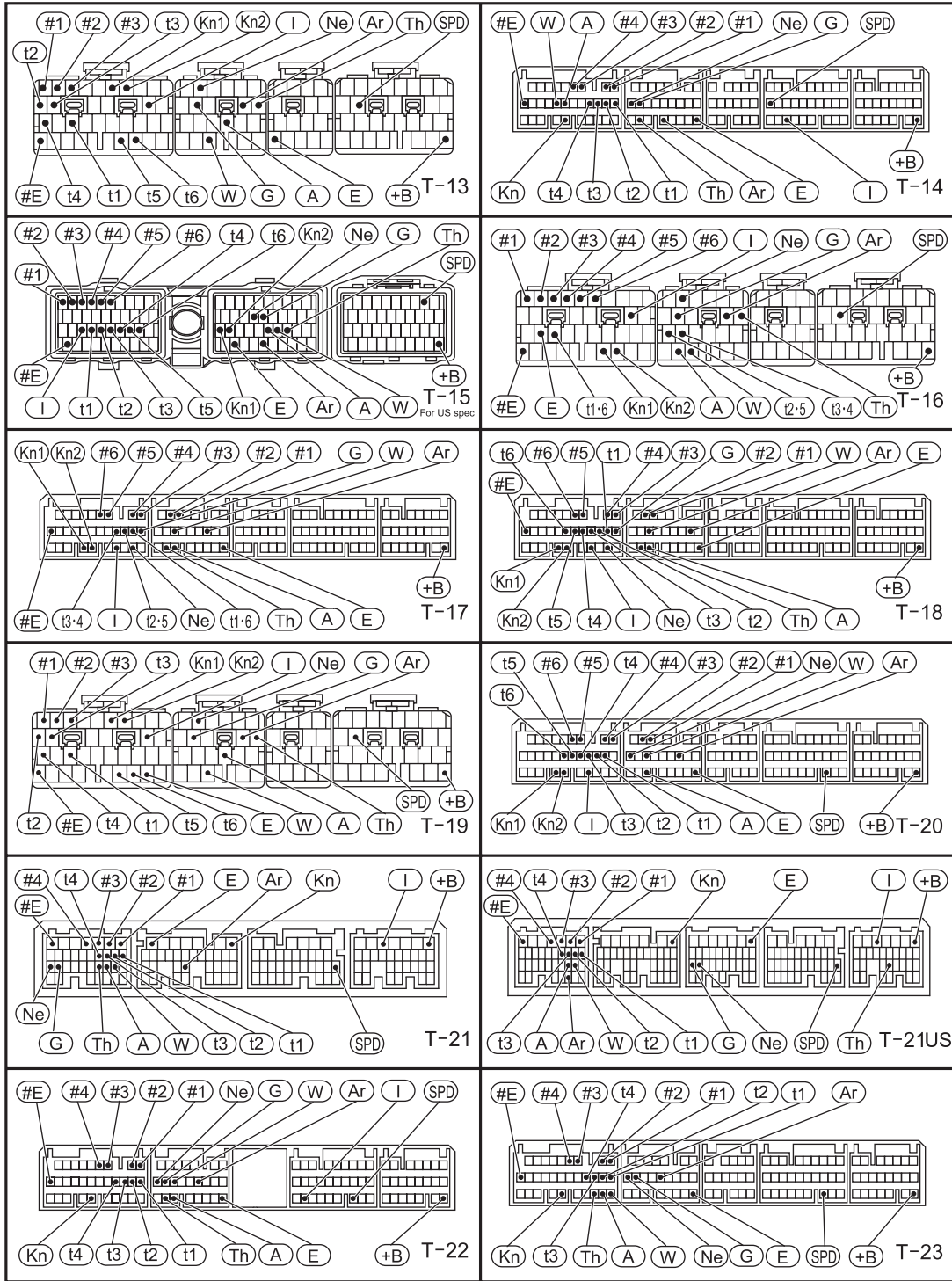

16. ECU Wire Location Chart

16. ECU Wire Location Chart

NISSAN / INFINITI

Model	Chassis Code	Year	Engine Code	Sensor Type	CP #	ECU Location
SKYLINE	BNR34	99.1~01.4	RB26DETT	NS_HW-6	N-4	4
	ER34	98.5~01.5	RB25DET	NS_HW-5	N-10	
	BCR33	95.1~98.12	RB26DETT	NS_HW-6	N-4	
	ECR33	95.1~98.4	RB25DET	NS_HW-5	N-6	
		93.8~94.12		NS_HW-3		
	BNR32	89.8~94.12	RB26DETT	NS_HW-6	N-4	
HCR32	98.5~93.7	RB20DET	NS_HW-3	N-5	5	
G35 coupe	CPV35	03 ~	VQ30DE	NS_HW-12		N-12
350Z	Z33					
300ZX	Z32	89.7~02.6	VG30GETT	NS_HW-2	N-3	
			VG30DET			
240SX	S14	96 ~ 98 95	KA24DE	NS_HW-7	N-10 N-10	4
SILVIA	S15	99.1~02.1	SR20DET	NS_HW-7	N-8	4
			SR20DE		N-7	
	S14	96.6~98.12 93.10~96.5 93.10~98.12	SR20DET	N-8		
			SR20DE	N-2		
				NS_HW-8	N-7	
	PS13	91.1~93.9	SR20DET	N-9		
SR20DE			N-7			
180SX	RPS13	96.8~99.1	SR20DET	NS_HW-8	N-8	4
		91.1~93.9			N-9	
PULSAR	RNN14	90.8~94.12	SR20DET	NS_HW-7	N-7	2

Some of these information are for Japanese spec Vehicles. Please refer to you factory service manual.

16. ECU Wire Location Chart

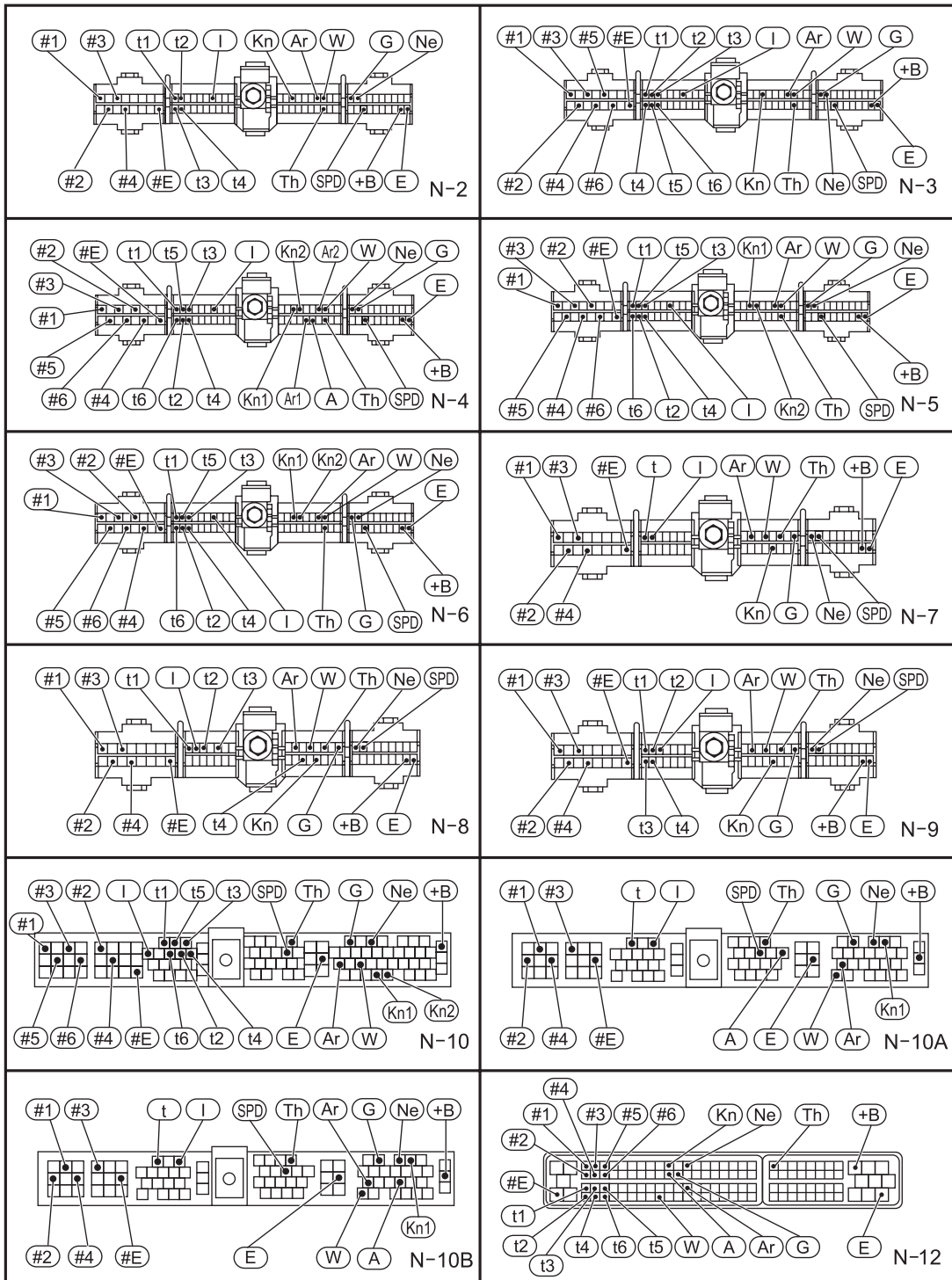

16. ECU Wire Location Chart

HONDA / ACURA

Model	Chassis Code	Year	Engine Code	Sensor Type	CP #	ECU Location
CIVIC	EP3	01.10~	K20A	HN_PR-4	H-7	3
	EK9	98.9~00.9	B16B (Type-R)	HN_PR-1	H-1	4
		97.6~98.8			H-2	
	EK4	98.9~00.9	B16A		H-1	
		95.9~98.8			H-2	
	EG6	91.9~95.8			H-3	
	EG9	91.9~95.8				
EJ1	93.2~00.8					
RSX	DC5	01.7~	K20A	HN_PR-4	H-7	3
INTEGRA	DC2/DB8	95.9~01.6	B18C(Type-R)	HN_PR-1	H-2	4
		93.5~95.8	B18C(M/T)		H-3	
		93.5~01.6	B18C(A/T)		H-5	
PRELUDE	BB6/BB8	96.12~98.9	H22A	HN_PR-1	H-2	5
	BB4	91.9~96.10			H-3	
ACCORD	CL1	00.6~01.5	H22A	HN_PR-1	H-1	3
	CF4	97.9~	F20B			5
	CD5	93.9~97.8	F22B		H-3	
NSX	NA1	90.9~97.1	C30A	HN_PR-3	H-8	9

Some of these information are for Japanese spec Vehicles. Please refer to you factory service manual.

16. ECU Wire Location Chart

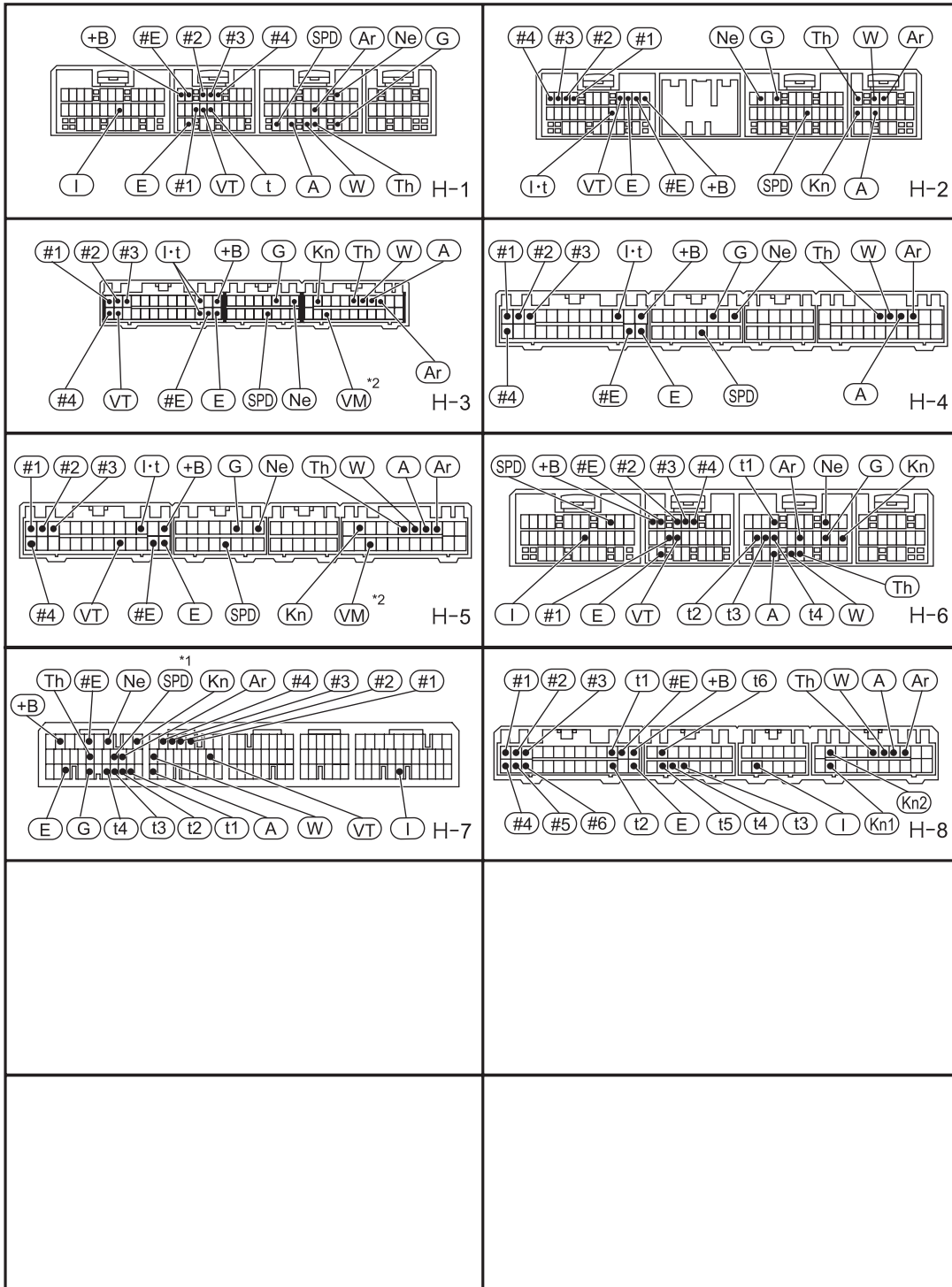

*1 MT only

* 2 Vehicle with VTM Signal

16. ECU Wire Location Chart

MITSUBISHI

Model	Chassis Code	Year	Engine Code	Sensor Type	CP #	ECU Location
LANCER	CT9A	03.1~05.2	4G63	MT_KR-1	M-9	4
	CT9A	01.2~02.1				
	CP9A	98.1~01.1			M-5	
	CN9A	96.8~97.12				
	CE9A	93.12~96.7			M-2	
	CD9A	92.10~93.11				
3000GT	Z16A	90.10~99.8	6G72	MT_KR-2	M-1	2
ECLIPSE	D32A/D33A	95~99	4G63	MT_KR-1	M-5	4
	D39A		4G64 (2.4L)			
	D22A/D27A	89~91		M-2		
	D53 M/T	01~05	6G72 (3.0L V6)	MT_KR-2	M-9A	
	D53 A/T				M-9B	

Some of these information are for Japanese spec Vehicles. Please refer to you factory service manual.

16. ECU Wire Location Chart

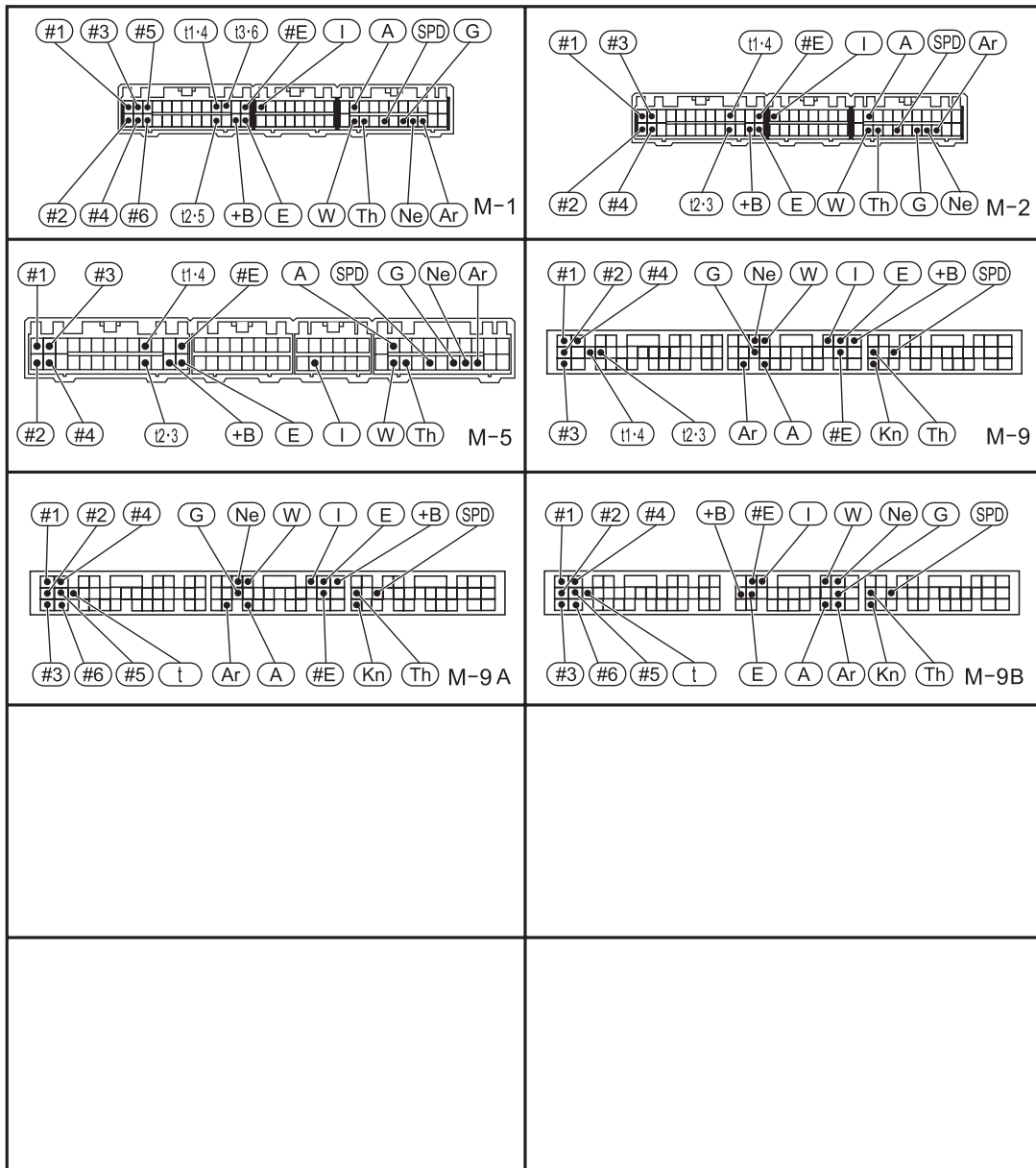

16. ECU Wire Location Chart

MAZDA

Model	Chassis Code	Year	Engine Code	Sensor Type	CP #	ECU Location	
RX-8	SE3P	03.4~	13-MSP _(M/T)	MZ_HW-5	MA-11	11	
			13-MSP _(A/T)		MA-10		
COSMO	JCESE	90.3~95.8	20B-REW	MZ_FL-5	MA-1	5	
	JC3SE		13B-REW	MZ_FL-3	MA-2		
RX-7	FD3S	95.12~	13B-REW		MZ_PR-1	4	
		91.12~95.11			MA-3		
	FC3S	89.3~91.11	13B		MZ_FL-2	MA-6	5
		85.9~89.2			MZ_FL-1	MA-8	
MIATA	NB8C	98.1~00.6	BP-ZE	MZ_HW-1	MA-5	5	
	NB6C		B6-ZE				
	NA8C	95.8~97.11	BP-ZE	MZ_HW-3	MA-13		
		93.8~95.7			MA-12		
	NA6CE	89.9~93.7	B6-ZE	MZ_FL-4	MA-7		

Some of these information are for Japanese spec Vehicles. Please refer to you factory service manual.

16. ECU Wire Location Chart

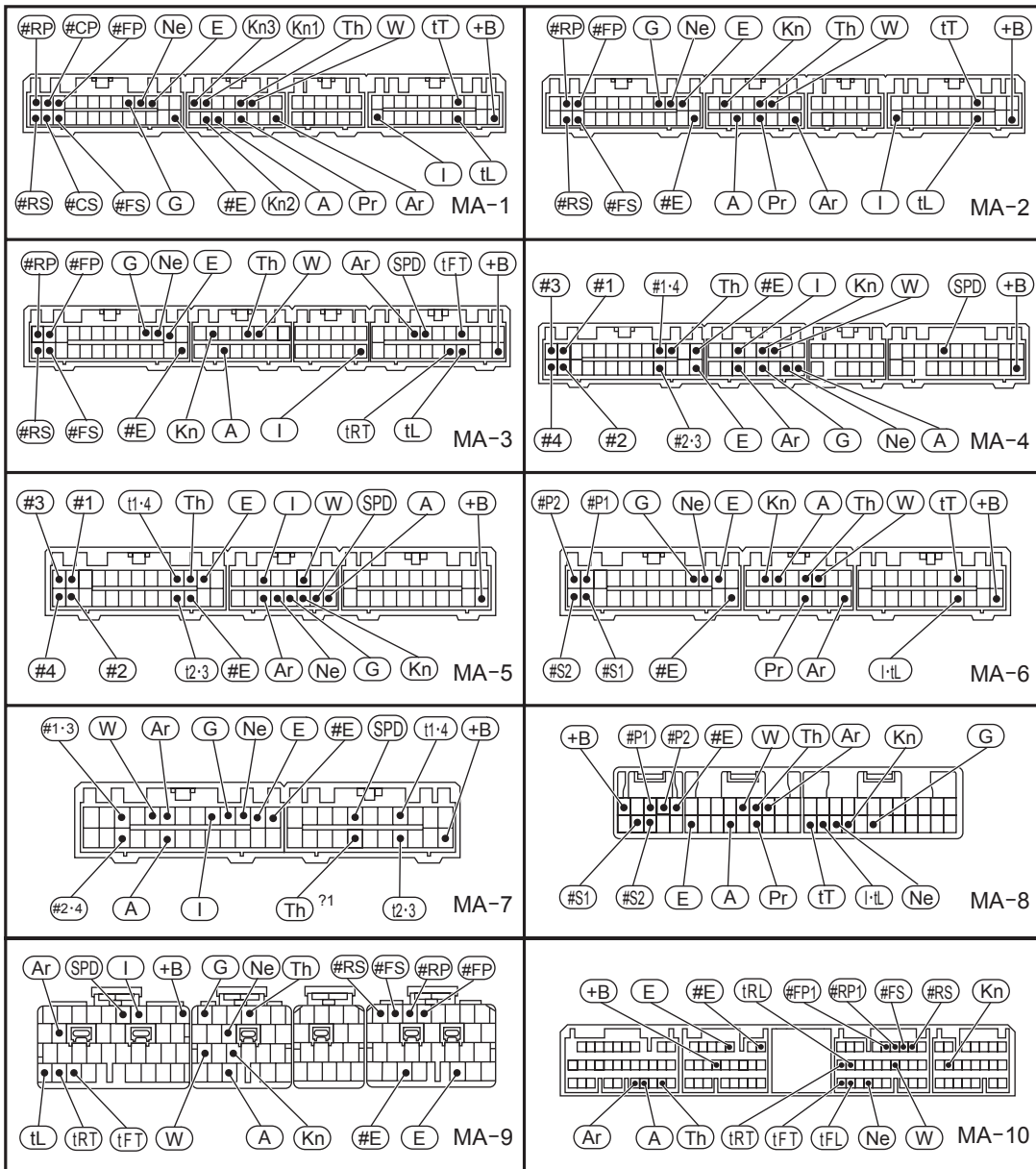

16. ECU Wire Location Chart

SUBARU

Model	Chassis Code	Year	Engine Code	Sensor Type	CP #	ECU Location
LEGACY	BH5/BE5	98.6~	EJ20	SB_HW-4	F-6	5
	BD5/BG5	96.6~98.5	EJ20(M/T)	SB_HW-3	F-4	
		93.10~96.5	EJ20	SB_HW-1	F-2	
	BC5/BF5	89.2~93.9		SB_HW-2	F-1	
IMPREZA	GDFC	03~	EJ25	SB_HW-6	F-7A	5
	GDB/GDA	00.10~04.5	EJ207	SB_HW-6	F-7	5
	GC8/GF8	98.9~00.8	EJ20	SB_HW-4	F-5	5
		96.9~98.8		SB_HW-3	F-3	
		92.11~96.8		SB_HW-2	F-2	
FORESTER	SF5	98.9~	EJ20	SB_HW-4	F-4	5

Some of these information are for Japanese spec Vehicles. Please refer to you factory service manual.

16. ECU Wire Location Chart

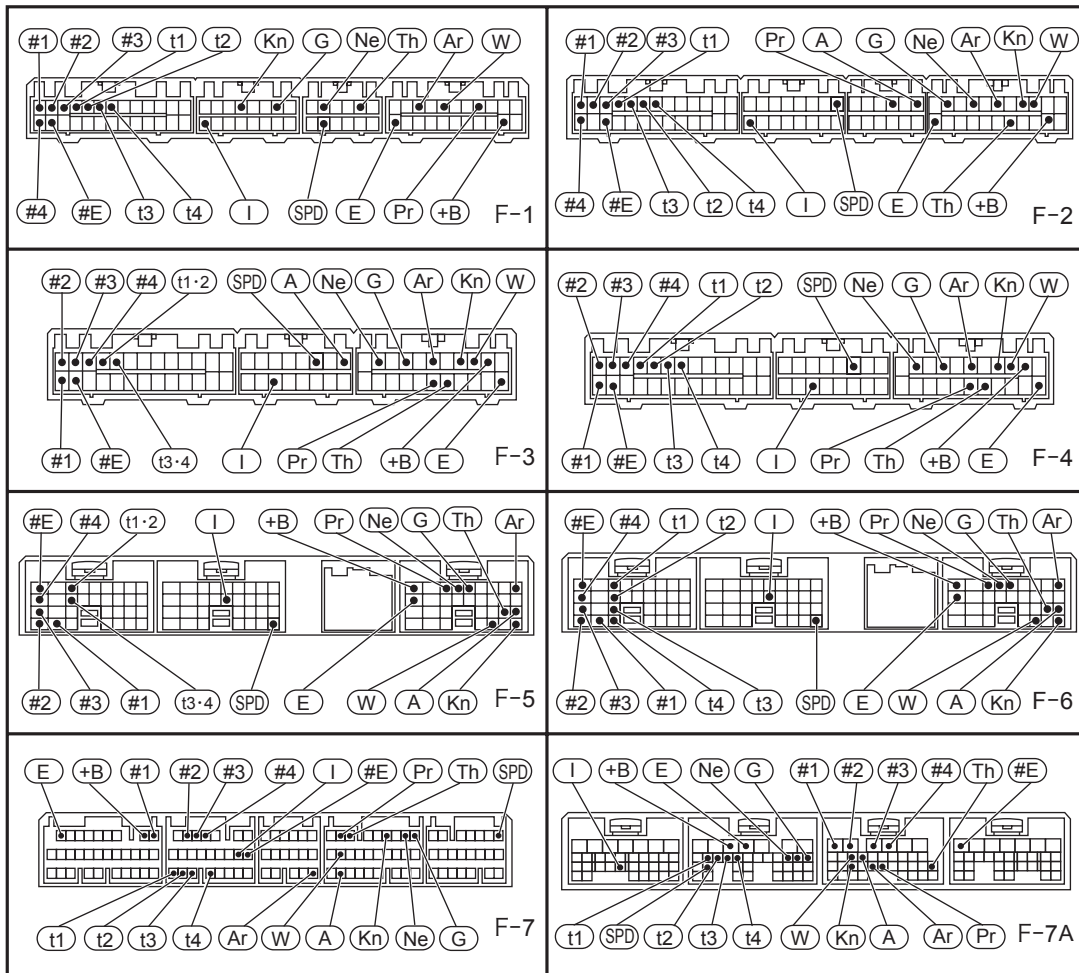

Notes

